

Photovoltaic UPS

S. Jayasimha and T.P. Kumar
Signion Systems Ltd.
71&72, Anrich Industrial Estate, IDA Bollaram
Medak District, A.P., India 502325
info@signion.com

Abstract—A low-cost battery management relay controller, enabling near-optimum utilization of a solar photovoltaic array, connected to an off-the-shelf uninterruptible power supply, for daytime grid-connected operation, is described.

1. INTRODUCTION

Electrical energy demand, at prices affordable by the masses, is rapidly outstripping supply, leading to lop-sided sector contributions (as well as growth) and increased unaccounted losses, e.g., Andhra Pradesh (Table 1) [1], where annual 2002 generation was estimated at 30×10^9 KWH realizing US\$2.4 billion (or \$0.08 per kWh).

Table 1. Andhra Pradesh's sectoral electricity demand contributions and growth

Segment	Contribution to total 2002 demand	Annualized (1994-2002) growth
Domestic	21%	10.5%
Commercial	5%	12.3%
Agriculture	40%	0.3%
Industry	22%	-1.0%
Railways	4%	7.2%
Unaccounted	8%	16.8%
Overall	100%	3.1%

During 1994-2002, Andhra Pradesh's domestic and industrial LT electricity tariffs have escalated at annual compounded rates of 15.5% and 11.8%, while diesel fuel's price increase was 14.9%. In the same period, solar photovoltaic (SPV) module, lead-acid battery and diesel generator prices have remained static, while uninterrupted power supplies (UPS) prices have declined by 6% annually and the prime lending rate has declined from 13.25% to 6.5%. These trends, while increasing pressure (through regulatory measures) to reduce labor and energy costs via industrial automation, continue to have a negative seasonal impact on the industrial and service sectors (due to increased denial of service and associated downtime), motivating a fresh consideration, after 1970s' energy shock, of renewable (particularly, for India¹, SPV) energy sources. Developed countries' post-1990 initiatives are:

- In the early 1990s, Germany subsidized a "1000 roof" private residence program by 50-60%
- Believing that SPV suited its geography and resources, and after studying technical barriers to its use, Japan

¹ e.g., [2] advocates solar energy to free tropical developing countries' rural populace from their "ship-to-mouth" dependence on imported fossil fuels.

sponsored a 577 private residence program (in 1994, it was extended to 1023 further residences), each of 3kWp [3]. By 2010, Japan will install 4.6GWp of SPV arrays.

- In June 1996, Clinton announced a million roof SPV program to be completed by 2010
- The EU plans 500,000 SPV roofs by 2010 (in the Netherlands, Switzerland and Belgium)

SPV's advantages are:

- Reduced greenhouse and other emissions
- Zero noise
- Easy integration with existing power converters
- Promising developments in materials technology that will enable reduced array/ controller cost

Technological barriers yet to be overcome are:

- Energy consumed in the production of crystalline SPV modules exceeds lifetime energy generated by them
- SPV modules' high manufacturing costs

Disparities in the Earth's conventional energy resource distribution diminish the first barrier's significance, with some areas endowed with huge fossil fuel reserves, while others may access virtually "free" hydroelectric or geothermal (see [4] for locations in India) resources. For example, eastern Indian states have surplus perennial hydroelectric energy, while southern states suffer chronic energy and water shortages in summer. Surmounting such seasonal and geographical vagaries is limited by capital available (for storage and distribution infrastructure); scheduling and siting of SPV manufacture may help "store" and "distribute" these otherwise wasted resources.

The predominantly urban \$100 million Indian UPS market, growing 22% annually (Table 2), fulfils a need for quality power with back-up. SPV array use would proliferate if they were to easily integrate with off-the-shelf UPSs (leveraging the latter's manufacture, distribution and service economies of scale). As Figure 1 illustrates, an SPV-augmented, grid-connected UPS improves reliability at lower cost when compared to a UPS with or without DG backup (potentially out-pricing grid power). A "use available power" paradigm improves return on investment by:

- Matching the SPV array's peak kW rating to a typical base load (grid power making up the deficit)

- Adapting state-of-charge (SOC) of a reduced AH battery-bank (reducing capital and recurring expenses) to optimize and “stream” SPV array power directly to the load
- Managing demand to match the SPV array’s power

Table 2. Indian UPS market segments and growth

Segment	% share	Annual growth	Factors favoring SPV over diesel gensets (DGs)
IT and Telecom	75%	10%	Noise, space, inconvenience of handling fuel/lubrication
Hospitals/clinics	10%	30%	Remote locations, criticality of service
OLTP (e.g., finance and transportation)	6%	25%	-
Residential			Noise, space, fuel/lubrication handling
Other	4%	-	

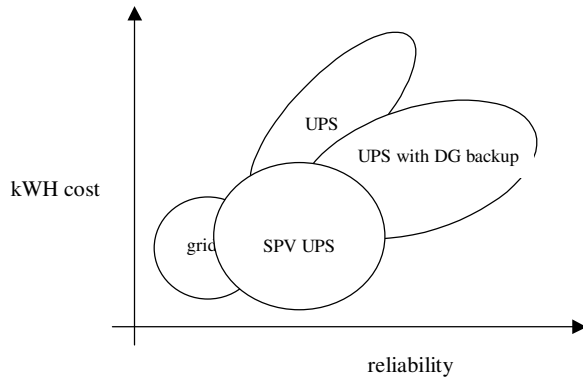

Figure 1. SPV UPS’s (and its alternatives) cost-benefit

2. MODIFICATIONS TO ON-LINE² UPS

While an appropriate dc-dc converter may deliver, irrespective of battery SOC, SPV power at the dc link voltage (decoupling optimum SPV array utilization from battery management), its size will vary with UPS rating. This pigeon-holing of converters, based on ratings, is difficult to support during nascent SPV/ UPS integration. Moreover, even 5% SPV power conversion inefficiency, in the absence of proper (and expensive) thermal management, may increase incidence of power converter failures.

An efficient and inexpensive alternative, that simplifies thermal management, uses diodes and relays to couple the SPV array to the UPS’s dc link and battery buses (Figure 2), trading away the ability to independently control battery charging and optimum SPV power delivery. This simple arrangement³ also compromises the ability to increase back-up (by using a larger AH battery bank⁴).

² While on-line UPSs provide superior power quality, omitting Figure 2’s SPV array to dc link bus relay allows off-line UPSs (or ‘inverters’), using the same measurements, to be similarly modified and controlled.

³ One design for single-phase input SPV UPSs (including controller, its MOSFET controlled relays, power-supply, and coupling diodes) supports dc link voltages from 70-240V and ratings from 0.5-10 kVA, while another

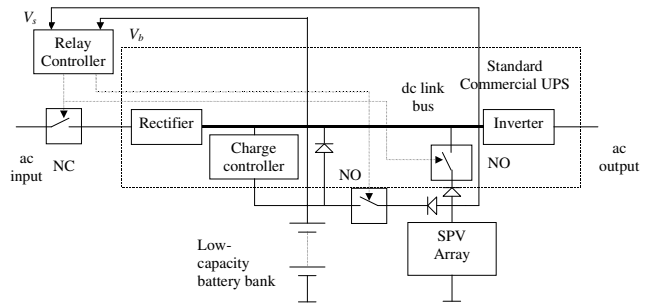

Figure 2. Line diagram of photovoltaic UPS

3. SPV CHARACTERISTICS

If V_{pv} , I_{pv} and I_{sc} are the operating voltage, current and short circuit current respectively (at a nominal temperature, say 25°C) of an SPV array, consisting of M parallel strings, each containing N serial cells, then [5]:

$$V_{pv} = \frac{N}{\lambda} \cdot \ln \left(\frac{I_{sc} - I_{pv} + M \cdot I_0}{M \cdot I_0} \right) - \frac{N \cdot R_s \cdot I_{pv}}{M} \quad (1)$$

Parameters depend on cell material and manufacturing process; e.g., Bharat Electronics’ boron-doped 125 mm pseudo-square, 325 μ m thick single crystal solar cell (with typical measured V_{oc} =590mV, I_{sc} =4.4A) has I_0 = 5×10^{-5} A (reverse saturation current), R_s =25m Ω and λ =19.297 ($\approx \ln[I_{sc}/I_0]/V_{oc}$). The array of Figure 11 has 42 photovoltaic modules, each comprising 36 serial cells, with N =252 and M =6. Its V - I and P - I characteristic, at multiples of 20% of STC solar intensity (1kW/m²), are shown in Figure 3.

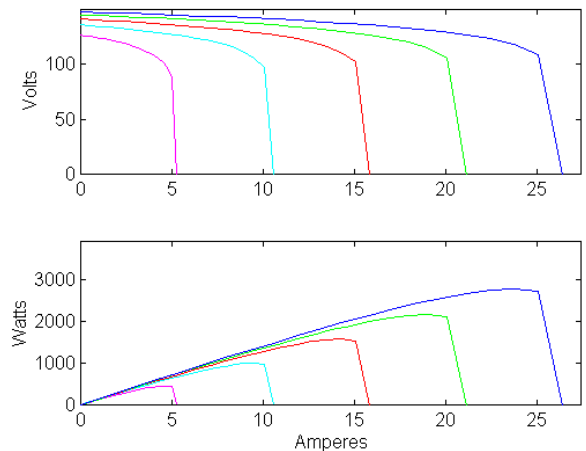

Figure 3. SPV array’s voltage and power vs. current with varying solar intensity

The SPV array’s open circuit voltage, V_{oc} is:

design for 3-phase input supports dc link voltages up to 350V and ratings from 10-20kVA.

⁴ Two more relays that isolate a parallel battery bank, while maintaining it at full charge, during normal operation will enhance backup duration. The parallel battery bank’s AH rating, a trade-off between desired night-time backup and battery cost, is non-zero only for atypical remote-area use.

$$V_{oc} = \frac{N}{\lambda} \cdot \ln\left(\frac{I_{sc}}{M \cdot I_0} + 1\right) \quad (2)$$

The SPV array's maximum power voltage, V_{mp} , is V_{pv} when $V_{pv} \cdot I_{pv}$ is maximal. At maximum power, $dV_{mp}/dI_{mp} = -V_{mp}/I_{mp}$, I_{mp} being the current at maximum power, implies:

$$\frac{1}{I_{mp}} \ln\left(1 + \frac{I_{sc} - I_{mp}}{M \cdot I_0}\right) - \frac{1}{M \cdot I_0} \left(1 + \frac{I_{sc} - I_{mp}}{M \cdot I_0}\right)^{-1} = \frac{2\lambda \cdot R_s}{M} \quad (3)$$

Since $(I_{sc} - I_{mp}) \gg M \cdot I_0$, I_{mp} has a practically linear relationship to I_{sc} and, except when $I_{pv} \cdot R_s$ becomes significant at high solar irradiance, V_{mp} varies linearly with V_{oc} . Figure 4 shows relations between the SPV array's I_{sc} , I_{mp} , V_{oc} and V_{mp} .

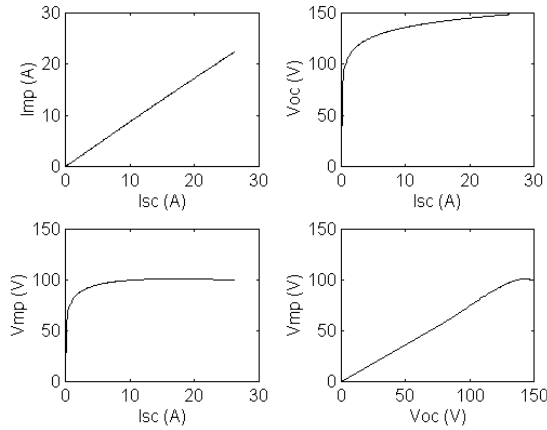

Figure 4. Relationship between SPV array parameters

Given V_{oc} and V_{mp} at temperature θ_1 , their values at a different temperature θ_2 are given by:

$$\begin{aligned} V_{oc}(\theta_2) &= V_{oc}(\theta_1) - \beta_{V_{oc}} \cdot V_{oc}^{STC} \cdot (\theta_1 - \theta_2) \\ V_{mp}(\theta_2) &= V_{mp}(\theta_1) - \beta_{V_{mp}} \cdot V_{mp}^{STC} \cdot (\theta_1 - \theta_2) \end{aligned} \quad (4)$$

V_{oc}^{STC} and V_{mp}^{STC} are voltages expected at ASTM standard conditions ($1\text{kW}/\text{m}^2$ irradiance at 25°C). The temperature coefficients, $\beta_{V_{oc}}$ and $\beta_{V_{mp}}$, are approximately equal (with less than 5% error [6] and independent of solar irradiance).

Thus, the SPV array's operating voltage is controlled based on the following premise: V_{mp} , despite varying as a function of temperature and irradiance, is directly proportional to V_{oc} .

4. LEAD-ACID BATTERY CHARACTERISTICS

A lead-acid⁵ battery (nominally rated at 12V) has [7]:

- A linear open-circuit voltage of 11.4 -13.4V over 0-1 of its nominal ampere-hour (AH) SOC (see figure 5)
- 25m Ω battery discharge resistance for 12.2-13.4V open circuit voltage (0.4-1 SOC), which increases linearly to 100

⁵ Lead-acid is the chemistry of choice for SPV and backup power systems. High coulometric efficiency (75-85%) true deep-cycle batteries, that may last 20 years with a controlled charging and operating temperature regimen, are now available. For example, morning charging in tropical conditions is preferred (as each 10°C temperature rise halves battery's cycle life).

m Ω as open circuit voltage ranges over 12.2-11.4V (0.4-0 SOC)

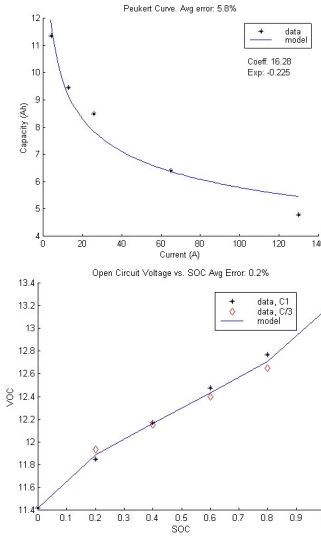

Figure 5. Lead-acid battery characteristics

Maintaining 0.4-1 batteries' SOC⁶ in the 25% (i.e., at 7:00AM or 5:00PM in the tropics) to 100% (at noon) solar intensity minimally provides 40% battery back-up for an early morning or late afternoon power outage⁷.

To match these ranges, N_b , the number of serial batteries, and the number of serial, N , and parallel, M , solar cells, are chosen to satisfy $V_{mp}^{0.25 \text{ STC}} \cong N_b \cdot V_b^{0.4 \text{ SOC}}$, provided that V_{oc} is less than the UPS's dc link voltage when the minimum acceptable ac input voltage is present.

5. CONTROLLER DESIGN

Measuring V_{oc} and battery-charging (to V_{mp}) using grid or SPV energy, the controller minimizes daytime grid energy and actuation (battery and relay life-cycle) costs as follows:

- Momentary disconnection of the SPV array from the UPS's dc link bus and the battery allows V_{oc} sampling (ac mains, or, if absent, the battery-bank, supporting the load).
- If $V_{oc} < V_T$, a voltage threshold below which the solar array's power output is insignificant, the ac duty cycle, ρ , of the ac mains relay is set to 1 (for night-time, solar eclipse, early dawn and late dusk operation)
- The battery's SOC is changed so that operation at V_{mp} occurs (higher solar irradiance requires higher SOC) by a proportional controller⁸ computing $\rho = K \cdot [L(V_{oc}) - V_b]$, $0 < \rho < 1$, and $L(\cdot)$ is a fixed (linear) map from V_{oc} to V_{mp} , with ac mains connection being made at a PWM period's beginning.

⁶ While a low battery resistance (SOC > 0.4) regime ensures battery longevity, charging at SOC < 0.7 obtains > 90% coulometric efficiency.

⁷ From dusk onwards, full battery backup is available (since normal UPS operation resumes after a post-sunset battery-charging period).

⁸ For $\rho \neq 0$, the load power's excess over SPV power determines discharge rate. A constant additive term, M , in the computation of ρ (before limiting) may compensate for a high crest-factor load current (see Figure 9) that discharges the battery even when SPV power exceeds demand.

- K , a function of the UPS's battery charging current, I_c , and its AH, is based on the controller tracking V_{mp} and yet utilizing some SPV energy as the sun ascends. A derated battery (for a UPS primarily used during daytime), for a given I_c (usually proportional to UPS VA rating), charges quicker, and leads to better SPV energy use during sunrise.
- The maximum mean ac mains duty cycle, ρ_{av} , for the ascending sun period, T_r (approximately 90 minutes in the tropics), is $(S_{as}-S_{sr})/(I_c \cdot T_r)$, where S_{as} is the desired battery SOC (in AH) for the ascended sun, S_{sr} is the SOC at sunrise and I_c is the battery charging current.
- To minimize UPS tripping probability during the ascending sun period, $K=[1-\kappa(V_b-V_{bmin})]$, where κ is a gain scheduling multiplier and V_{bmin} is the minimum battery operating voltage of the UPS (where, typically, an audible alarm sounds). For example, at V_{bmin} , $\rho=1$.
- To avoid UPS tripping when SPV power is inadequate and ac mains absent, the PWM period, τ , is 25 seconds when V_{oc} varies significantly between consecutive sampling instants. Otherwise, a PWM period of 200 seconds extends relay life⁹ and ensures a negligible steady state performance loss (due to V_{oc} measurement).
- Grid power (through the UPS's rectifier and charge controller) charges the battery, at constant current, and with duty cycle ρ , to the desired SOC. The normally open (NO) relay of Figure 6 is activated after sampling V_{oc} (when $\rho=1$, this relay is deactivated upon the expiration of the current PWM period, in order to sample V_{oc} again) allowing SPV energy to augment grid-based battery SOC build-up.
- When the V_b time series shows a sluggish response to an active ac mains relay (the excess of SPV power over the load limiting the battery charging rate), grid power loss may be inferred and demand side management (DSM) initiated.

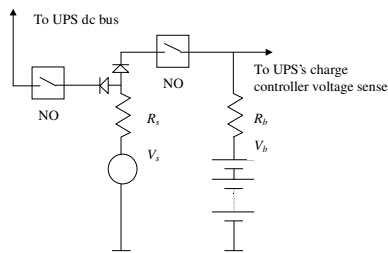

Figure 6. Battery charging¹⁰ using SPV array

6. CONTROLLER REALIZATION

Figure 7 shows a realization of a three-relay controller using a low-cost microprocessor.

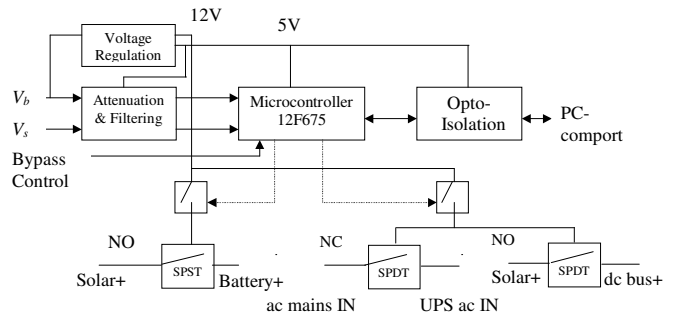

Figure 7. Relay controller schematic

The relay controller, through its port, may indicate anomalies detected by examining V_{oc} and V_{mp} , e.g.:

- a bad SPV-array-to-UPS-dc-bus relay or loose connection by analyzing V_s and V_b time series
- a battery voltage less than V_{mp} (when ac mains connected and present) is indicative of either a bad ac mains relay, a loose ac mains connection, or a bad battery in the bank)

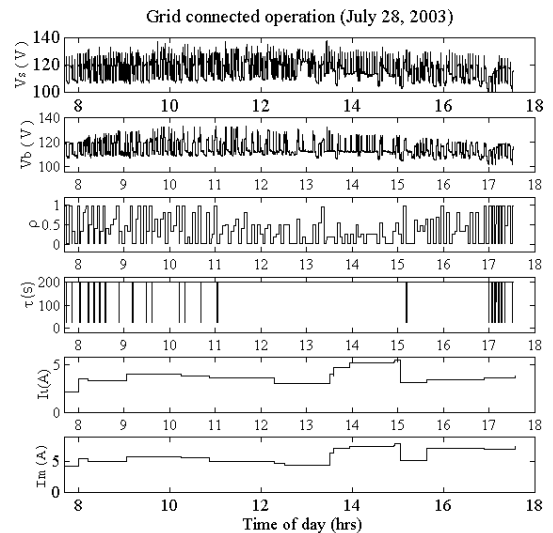
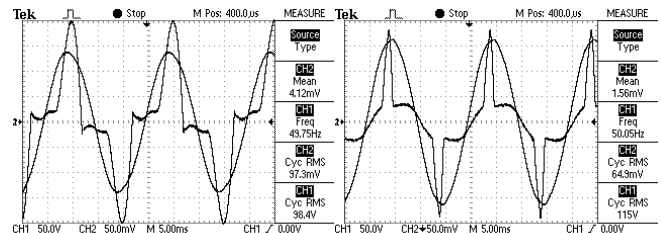

Figure 8. Grid-connected operation on cloudy day



(a) $pf=0.84$

(b) $pf=0.82$

Figure 9. UPS input (a) and output (b) voltage (sine) and current (peaky) waveforms

Figure 8 shows diurnal data, captured from the controller's serial port, with load current, I_l , hovering at $\sim 5A$ and mains current, I_m , when active, at $\sim 6A$. Also, Figure 9 shows the UPS input's power factor as 0.84 (due to the full-wave rectifier's load capacitance), while the load's power factor is

⁹ The 8-30ms activation time, 50 m Ω typical initial contact (silver alloy) resistance electro-mechanical relays (operated for 10 hours/day at ~ 25 cycles/hr) have 10^5 and 10^6 cycles contact life at full and 20% breaking VA, respectively. The dc relays (operated at only 20% of rated VA because open-relay voltages never exceed 30V) last 10 years, while the ac relay lasts 4 years (assuming that ac mains VA is 20% and 80% of full load VA during 8 sunny and 4 cloudy months annually).

¹⁰ A typical relay-based battery charger's current-limiting resistor is unnecessary when I_{pv}^{STC} (with a minimal 0.4 battery SOC $\bullet (V_{mp}^{STC} - V_{mp}^{0.25STC} - V_f) / (N_b \cdot 50m\Omega + N \cdot R_s / M)$, 3.5A for the described design) is less than the recommended cyclic battery charging limit.

0.82 (reflecting SMPSs in today's office equipment). Grid and load energies were 5.1kWH and 10.1kWH; thus, SPV energy (at load) was 5.0kWH. If automated scheduling of certain loads, described below, were implemented, SPV energy consumed (at load) would increase by almost 2kWH.

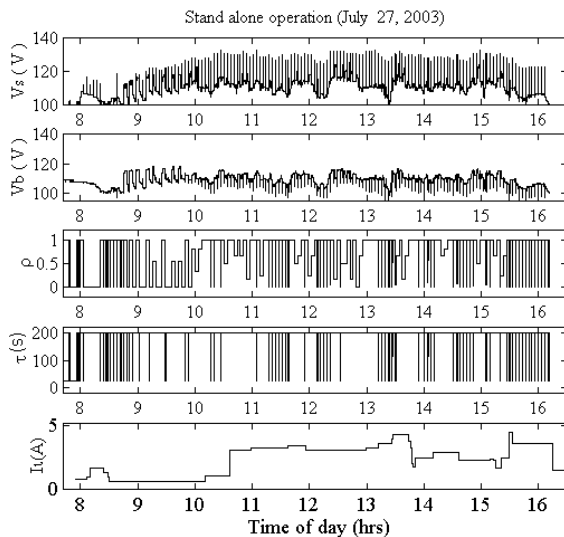

Figure 10. Stand-alone operation on overcast, rainy day

Figure 10 illustrates stand-alone SPV UPS operation on a rainy day, where ρ , the duty cycle of SPV-based battery-charging, is just sufficient to allow maximum power to be delivered by the SPV array. Even under such adverse operating conditions, the SPV UPS, with DSM enabled, delivered 5.2kWH.



Figure 11. Photovoltaic UPS and array

The working economics of the SPV UPS, pictured in Figure 11, are shown in Table 3. Renewable¹¹ energy utilization, especially for prolonged grid outage regimes, is enhanced when a demand-side automation system:

- Prioritizes and segregates loads (with separate relays)
- Schedules non time-critical low duty-cycle loads (many water pumps, air circulators and some lights fall in this category) automatically (also eliminating human switcher costs, e.g., automatic gate, entry and intrusion detection systems). Examples of loads, that are necessarily switched

¹¹ Automation also plays a role in non-renewable backup, e.g., diesel generators; however, automated fuel delivery and availability guarantees are difficult to achieve

by humans and cannot be so scheduled, are projectors, inspection lights and manually operated electrical tools.

- Puts some systems (e.g., computer monitors) into low-power or standby modes
- Uses automatic sensor (temperature, moisture, humidity, pressure, level, luminosity, motion, etc.) and availability based load-scheduling
- Provides audible imminent shutdown warning
- Shuts down (computer) systems automatically

Table 3. Working Economics

Capital costs (for 3kWp array)	Rs. 616,200
PV array: Rs 466,200 [#]	
UPS: Rs.115,000 [#]	
Structural: Rs. 20,000	
Batteries: Rs. 15,000 [*]	
[#] in 1994 [*] 3 year life	
Annual maintenance	Rs. 8,000
2002 savings @3600 kWh/annum (tariff/ η_{ups} ; $\eta_{ups}=0.85$)	Rs. 22,058
Annual amortization of SPV array (over 20 years, with interest)	Rs. 25,000
Subsidy for viability	10-20%
Unaccounted benefits	<ul style="list-style-type: none"> • 100% depreciation • Regulated power • Noiseless environment • Reduced capital and maintenance in de-rated battery

7. CONCLUSION

A method that efficiently utilizes SPV arrays connected to UPSs is described. Certain service industries, that already use UPSs in their operations, can easily afford this solution.

REFERENCES

- [1] Andhra Pradesh Electricity Regulatory Commission website, www.ercap.org
- [2] F. J. Dyson, *The Sun, the Genome, and the Internet: Tools of Scientific Revolutions*, Oxford University Press, ISBN 0195139224.
- [3] Y. Hamakawa, "An Accelerated Promotion of the New Sunshine Project and Recent Advances of PV Technologies in Japan," *Proc of ISES '97*, WSC, Taejon, Korea, Aug., 1997.
- [4] D. Chandrashekaram, "Geothermal Energy Resources of India," *Proc. Of Geothermal Power Asia 2000*, Manila, Feb., 2000.
- [5] M.A. Green, *Solar Cells: Operating Principles, Technology and System Applications*, Prentice-Hall, NJ, 1982, ISBN 0858235803.
- [6] D.L. King, J.A. Kratochvil, and W.E. Boyson, "Temperature coefficients for PV modules and arrays," *Proc. of 26th IEEE PV Specialists Conference*, Sept., 1997.
- [7] D. Berndt, *Maintenance-Free Batteries*, New York: John Wiley and Sons, 1997.